

spinlock

2011

PRODUCT GUIDE

GBR

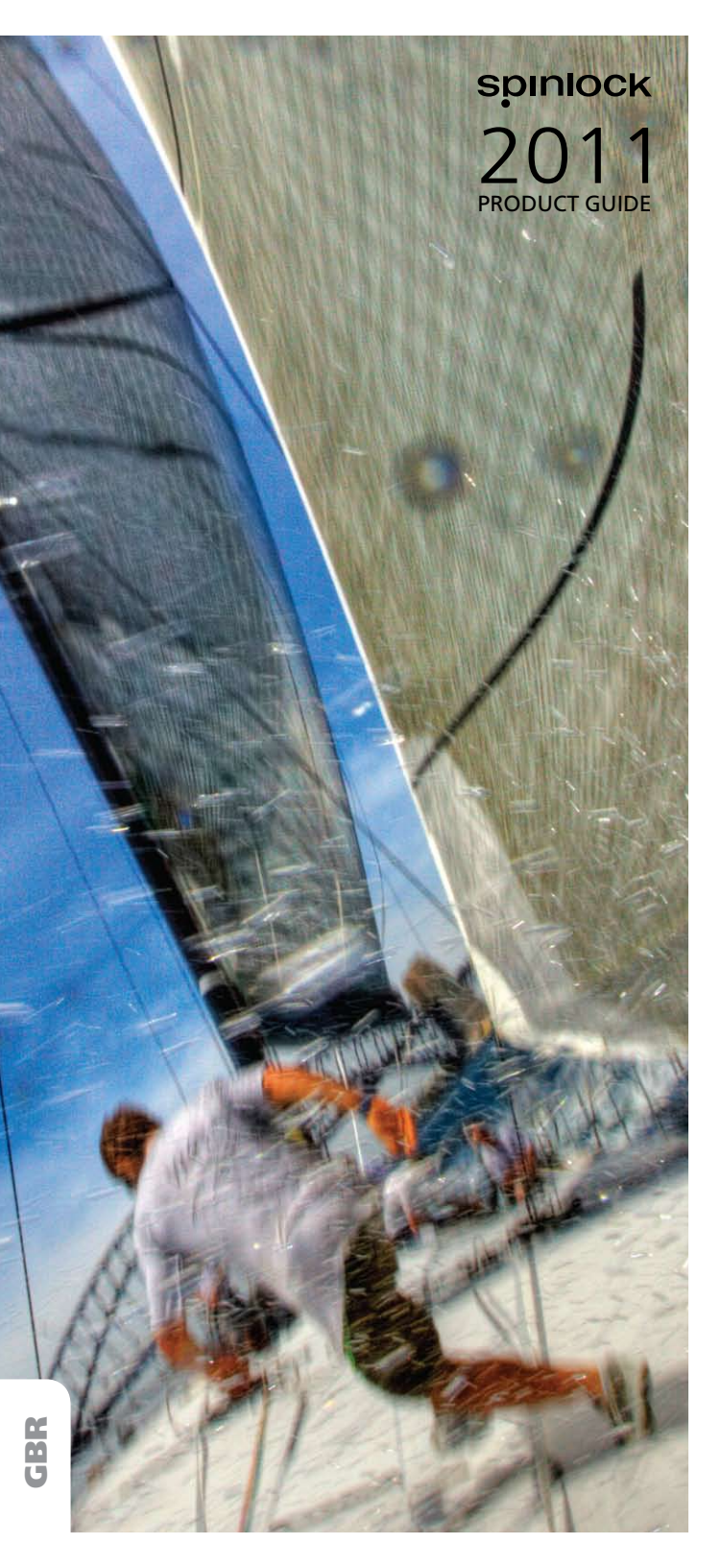

# SPINLOCK

WELCOME TO  
SPINLOCK

2011

---



New advances in sailing performance are testing people and equipment like never before. Here are some of the ways Spinlock designers are making the new performance possible.

New generation Clutches and Jammers to ensure consistent loadholding and safe release of advanced performance ropes.

And new ZERO sport-sailing vests and Deckvests to help crew work under extreme conditions, faster, better and more safely.

There's room in these pages for essential details, but take a look at [www.spinlock.co.uk](http://www.spinlock.co.uk) and you'll find a lot of other useful information.

View one of the training videos-or the Spinlock Suggests App and see what we recommend for you and your boat.

Or, if you prefer, email or phone Spinlock pro support instead!



TECHNICAL  
SUPPORT

# ONLINE

In-depth advice and information  
on all things Spinlock

**[www.spinlock.co.uk](http://www.spinlock.co.uk)**

New features include:

Interactive product selection guide  
Installation & maintenance videos  
Product instructions  
2D & 3D CAD files  
Drill templates

One to One email support:  
**[prosupport@spinlock.co.uk](mailto:prosupport@spinlock.co.uk)**

Special Projects Team, technical support for  
designers, project managers and builders:

**[spt@spinlock.co.uk](mailto:spt@spinlock.co.uk)**

design by Simon Udal Design Ltd  
[www.simonudaldesign.co.uk](http://www.simonudaldesign.co.uk)

cover image courtesy of  
Christophe Launay

Spinlock Limited quality  
management system is  
accredited to:  
**EN ISO9001:2008**  
by SGS Quality Assurance





# Deckvest Range - LjH Lifejacket Harness

Complete Man Overboard Protection

Unequaled comfort in all conditions (ISO certified 150 & 275N)

Compact high-agility shape, easily adjusted secure fit

Built-in deck harness with soft connection loop

5 year extended warranty



DW-LJH/A2

Pro-Sensor  
**150**

Sizes 1, 2 & 3



PRO-SENSOR



DW-LJH/H2

Hammar  
**150**

Sizes 1, 2 & 3



HAMMAR



DW-LJH/C2

Hammar  
**275**

Sizes 2 & 3



STORAGE POCKET



INFLATED

Fitted sprayhood and high intensity light

Comfortable thigh / crotch strap

CO2 cylinder status indicator window

Emergency safety line 'S' cutter included in storage pocket

'Manual Only' conversion kit available



# Zero Sports - BAM Flotation Vest

High agility sport sailing vest

For performance keelboat and sportsboat competition

Open powermesh panels and venting back enhances breathable layers



DW-BAM

Revolutionary ergonomic design

Stretch panels for unrestricted hiking/trapezing

Unique 'Body Fit' adjustment

Streamlined fit for any user shape

Lower back protector

Front access zip for relaxing between races



VENTING

Quick draining construction

Hand Warmer and essentials pockets

Available in sizes 1, 2 & 3

50N Buoyancy



# Knee Pads - KPD



DW-KPD

High density foam-moulded impact protection and patella support

Extra tough abrasion covers

Low volume back panel prevents bulking



DW-KPD





# Deckware Protection



DW-MPH

## Mast Pro - MPH

Unequalled for safe working on mast and foredeck

Safer than any bosun's chair

Extra wide leg straps and lumbar support

Anti-snag buckle covers

Pocket for ultra-light

Tripping Spike



SPIKE POCKET



DW-MPH



DW-STR/02

## Safety Lines - STR

The neatest way to secure every deck harness

Up to 50% lighter, more compact and easier to wear than conventional lines

Full strength compact 16mm webbing

Spinlock compact, lightened safety clips

Overload indicator

Cow hitch, Stretch, Two and Three Clip versions

ISAF/ORC Compliant



DW-STR/2LE



DW-STR/03



DW-STR/3L



# PXR Camcleat

Performance camcleat for instant cleating & release under load

More precise mast and deck line control

Unbeatable for single line spinnaker hoist systems

## PXR0206

Lines 2-6mm ( $\frac{3}{32}$  -  $\frac{1}{4}$ " )

Loads up to 140kg (616lbs)  
at max line diameter

## PXR0810

Lines 8-10mm ( $\frac{5}{16}$  -  $\frac{3}{8}$ " )

Loads up to 200kg (440lbs)  
at max line diameter



PXR0206

Hard anodised alloy cam and base

Integral fairleads

Angle line up to Release,  
down to Engage



PXR0810



PXR0206/SW

## DECK SWIVEL /SW

For single cleat control of  
jib sheets, dinghy vang and  
single line spinnaker hoist  
systems



PXR0810/SW



PXR0206/T

## RETROFIT /T

Upgrades mainsheet swivel  
cleats, travellers, downhauls,  
vangs and backstay controls

Fits any conventional  
camcleat hole spacing



PXR0810/T



PXR0206/VP

## CENTRE PIVOT /VP

Standard fit on top sportsboat & dinghy classes

For feeding control lines to sides, under-boom for  
outhauls, cat downhauls or vang

Mast bracket option



# XAS Powerclutch

The preferred clutch for racing yachts up to 27' and cruising yachts up to 34'

Easy access handle for effortless release

Lines 4-8mm ( $\frac{5}{32}$  -  $\frac{5}{16}$ " )

Lines 6-12mm ( $\frac{1}{4}$  -  $\frac{1}{2}$ " )

Loads up to 575kg (1270lbs)  
at max line diameter



XAS0612/1

0612 version for superb performance across the rope range

0408 high performance version for small diameter 4-8mm lines

High strength, soft grip handle

Replaceable parts, easy to upgrade & maintain

Single, Double & Triple Versions

Handle label set supplied



XAS0612/2

Use Continuous Line XAS0612/M for endless furling lines



XAS0612/3

Use Side Mountable XAS0612/HP or XAS0612 /HS (Port or Starboard) for spars, side decks and coamings



XAS0612/2



XAS0612/HP



XAS0612/3





# XTS/XCS Powerclutch

Reliable all-round performance across the rope range

The preferred option for larger production and race yachts, inshore and offshore

## XTS

Lines 6-10mm ( $\frac{1}{4}$  -  $\frac{3}{8}$ " )

Lines 8-14mm ( $\frac{5}{16}$  -  $\frac{9}{16}$ " )

Loads up to 1000kg (2200lbs)  
at max line diameter

## XCS

Lines 8-14mm ( $\frac{5}{16}$  -  $\frac{9}{16}$ " )

Lines 12-16mm ( $\frac{1}{2}$  -  $\frac{5}{8}$ " )

Loads up to 1200kg (2640lbs)  
at max line diameter



XTS0814/1

### XTS Series

0814 model for best rope holding on standard diameters

0610 high performance model for small diameter 6-10mm lines

Easy to upgrade & maintain  
Single, double and triple versions



XTS0814/2

### XCS Series

Solid alloy body to match your deck or rig

White (W), black (B) or silver (S) finished alloy



XTS0814/3



XCS0814/1S



XCS0814/2S



XCS0814/3S

Use Continuous line /M for endless furling lines

Use Side Mountable /HP or /HS for port/starboard for spars, side decks and coamings

Use Lock-open cam /L, for option to allow line to run freely, in and out.



XTS0814/HP



XCS0814/HPW



# ZR Jammer

Powerful 'hands free' jammer technology for production yachts  
Release action always safely controlled from the winch  
Ideal for performance cruisers 40'+

Lines 10-14mm ( $\frac{3}{8}$  -  $\frac{9}{16}$ " )  
Loads up to 1500kg (3300lbs)  
at max line diameter



ZR1014

Grip Switch selects Open or Winch-release modes  
Holds line loads 50% higher than XTS maximum  
High tensile fasteners, nuts and washers supplied  
One-piece jaw unit accessed with a single screw



ZR-JAW

**The ZR Jammer is ideal for:**  
Highly loaded lines where tension is critical  
Replacing an overloaded clutch  
Lines not usually released under load  
Halyards for furling sails  
Space-restricted 'dodger' locations  
Locations where an open clutch handle is a risk



SWITCH ON

**Not Recommended for:**  
Constantly adjusted lines  
Lines released fast under load  
Small diameter racing lines



ZR1014



SWITCH OFF



ZR1014

mid/high load ropeholding



# XX Powerclutch

The only secure fast-release solution for high load applications on performance yachts from 35-50 ft

With the latest XX jaws for higher line speeds

Lines 8-12mm ( $\frac{5}{16}$  -  $\frac{1}{2}$ "  
Loads up to 1800kg (3970lbs)  
at max line diameter



XX0812

New jaws for consistent holding of blended covered ropes

Smooth controlled release action

One-piece jaw set is easy to remove and clean

Black (B), White (W) or Silver (S) finish

Upgrade kit XX-KIT converts previous XX



XX0812/L

Lock Open version XX0812/L - for controls where locking the line is rarely needed

Switch UP: clutch mode

Switch DOWN : lines run in and out with handle closed



XX8012/HP

Upgrade kit XX-LCK converts to Lock Open

Side Mount - XX0812/HP or XX0812/HS (port or starboard) - for spar, side deck and coaming applications



XX0812 CTiC

## XXC0812 CTiC Series -

ultra light, ultimate load holding version

Lightweight titanium parts, ceramic coated jaws and carbon wrapped high load body



## Tiller Extensions - EA/EJ



EA/9005

Helps maintain optimum trim and visibility  
Cuts fatigue and improves concentration  
Telescopic extensions with precise push-button adjustment

Removable fast pin for easy stowage

**EA Series** - Asymmetric grip for secure all-weather helming



EJ/9005

**EJ Series** - Preferred for smaller cockpits, hiking and fast tacking

Compact racquet grip



## Organisers - T38/T50

Asymmetrical



T38/3Y

The neater line guide solution

Concentrates more lines in less space

38mm or 50mm sheaves

Flexes to fit the curve of the deck

Double-stacks to fit more lines if space is tight

Use Asymmetric model to save deckspace

Symmetrical



T50/3

Use TC50 alloy sheave models for higher loads



# ZS Jammer Range

Unrivalled performance for high line loads and larger diameters

New digital jaws hold high tech ropes securely at their safe working load

Lines 8-32mm ( $\frac{5}{16}$  -  $1\frac{1}{4}$ "")  
Loads up to 12000kg (26460lbs)  
at max line diameter



ZS0810

**ZS Alloy** - 3 versions for lines up to 18mm  
Massive wedge grip surface area  
Side mountable using existing holes in jammer body  
No risk of accidental release under high load



ZS1014C

**ZS Carbon** - 4 versions for lines up to 32mm  
Higher load capability-lower weight  
ZS Bonded for direct bonding to deck and spars  
ZS Handles engraved with line application  
Body colours to match hull, deck or spar finish



ZS0810/OPEN

**ZS Open** - 5 versions for lines up to 32mm  
Essential for peeling spinnakers, headsails, reefing or freeing a winch - Unbeatable in an emergency  
Easily attached to any strong point with a strop  
Hinged body can be opened and closed like a snatch-block



ZS ROPESENSE

**ZS RopeSense** - Compact Digital Load Cell  
Displays & logs actual line loads under sail  
Load capacity up to 50T  
Soft loop attachment to any line  
'Continuous' or 'Peak Load' readout  
Wireless Version - transmits to a PC



# Special Hardware

Innovative Deck Hardware solutions for your yacht to improve handling and control



WL/1 & WL/2

**Compact furling line guide system**  
Reduces line friction during furling  
Self aligning sheave for line entry and exit stanchions  
Straight line lead for other stanchions



BE06, 10, 12 & 16

**Neater line guides** for any deck  
Reduces snags on sails and lines  
Single screw fixing & self sealing gasket  
Stainless steel eyelet



TWF/63M

**Winchfeeder** for diverting lines to an alternative winch  
Two can be linked together with a TWF-BAR  
Very low profile 25mm (1")



RF/H

**Sail feeders** for a fast, smooth sail hoist  
Graphite bearing, anodised alloy rollers  
Mainsail feeder /MA slides into the mast track  
Headsail feeder /H guides flaked sail from deck to foil



ATCU

**Throttle control** with winch socket  
Stops risk of cockpit lines snagging  
Use Spinlock lever (ATCU-LVR) with standard Teleflex™ throttle





# TILLERS



## E-SERIES ACCESSORIES

- EA-HDL** Handle option asymmetric
- EJ-HDL** Handle option parallel
- E-GRIP** Tube sleeve grip
- E-DIABOLO** Stand up universal joint
- E-JOINT** Full swivel joint with fastpin
- E-SHOCK** Shock absorber
- E-SLEEVE** Replacement pivot housing
- E-FASTPIN** Full swivel joint release pin
- E-BUTTON** Control button
- E-CLIP** Tiller clip for all models
- E-KIT** Button, clip and sleeve

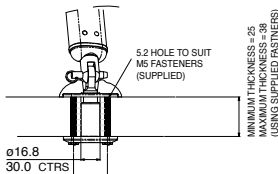
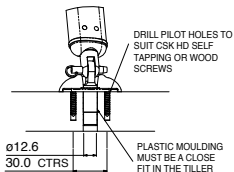

MODEL	WEIGHT	FASTENER TYPE
EA/900S	690g (24.2oz)	CSK HEAD (Supplied)
EA/1200S	780g (27.3oz)	CSK HEAD (Supplied)
EA/900DS	750g (26.3oz)	CSK HEAD (Supplied)
EJ/900DS	650g (22.8oz)	CSK HEAD (Supplied)
EJ/900S	445g (15.6oz)	CSK HEAD (Supplied)
EJ/1200S	510g (17.9oz)	CSK HEAD (Supplied)

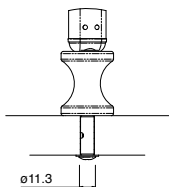

# ORGANISERS

Lines 14mm (9/16")  
Loads up to 1500kg (3300lbs)



MODEL	WEIGHT (exc fasteners)	FASTENER TYPE
T38	115g (4.0oz) + 30g (1.1oz) per sheave	CSK M6 (1/4")
T50	185g (6.5oz) + 45g (1.6oz) per sheave	CSK M8 (5/16")
TC50	575g (20.1oz) + 130g (4.6oz) per sheave	CSK A4-80 M8 (5/16") (Supplied)
TC50/D	750g (26.3oz) + 215g (7.5oz) per pair of sheaves	CSK A4-80 M8 (5/16") (Supplied)

## T38 & T50 ORGANISER ACCESSORIES

- TB11** alloy 38mm (1 1/2") TB series only (pre 2002)
- TB17** composite 38mm (1 1/2") TB series only (pre 2002)
- T38-C** composite 38mm (1 1/2") T38 series only
- T38-A** alloy 38mm (1 1/2") T38 series only
- T50-C** composite 50mm (2") T50 or TA (pre 2002)
- T50-A** alloy 50mm (2") T50 or TA (pre 2002)
- TB11 and TB17



# ZR

Lines 10-14mm ( $\frac{3}{8}$  -  $\frac{9}{16}$ " )  
 Loads up to 1500kg (3300lbs)  
 at max line diameter

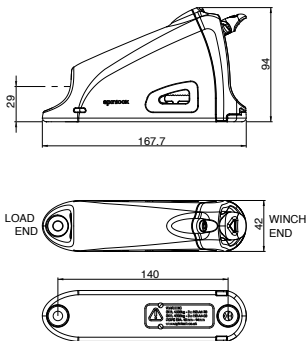
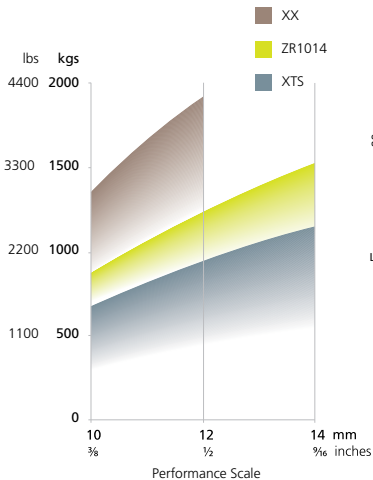

MODEL	WEIGHT	FASTENERS
ZR1014	394g (13.9oz)	2 x HEX M8 (5/16") (Supplied)

## ZR ACCESSORIES

**ZR-JAW10**  
 Replacement jaw assembly  
 for ZR1014

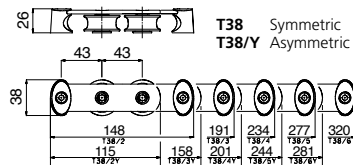

## TC50/D

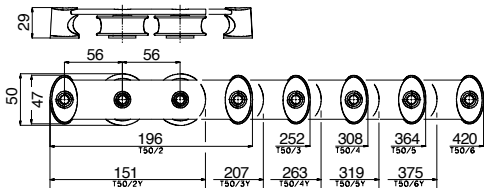
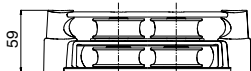

**T50** Symmetric  
**T50/Y** Asymmetric

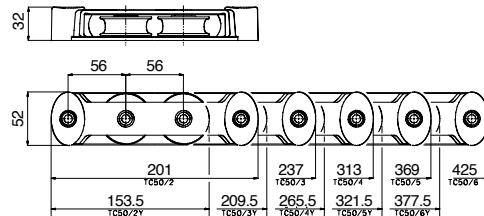



# XX



Lines 8-12mm ( $\frac{5}{16}$  -  $\frac{1}{2}$ " )  
 Loads up to 1800kg (3970lbs)  
 at max line diameter

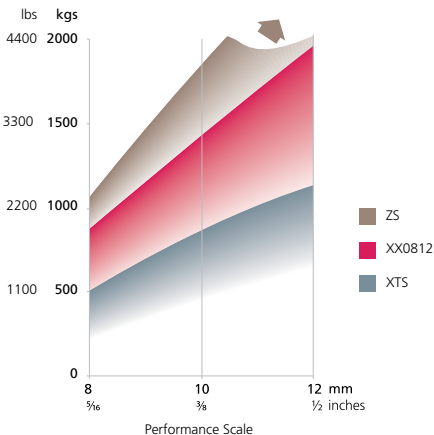

MODEL	WEIGHT	FASTENERS
XX0812	960g (33.9oz)	2 x HEX M8 (2 x 5/16") (Supplied)
XX0812-SMNT	1500g (52.9oz)	5 x CSK & HEX M6 (5 x 1/4") (Supplied)
XX0812/HP	960g (33.9oz)	5 x M6 x75mm (5 x 1/4") CSK & HEX (Supplied)
XX0812/HS	960g (33.9oz)	5 x M6 x75mm (5 x 1/4") CSK & HEX (Supplied)

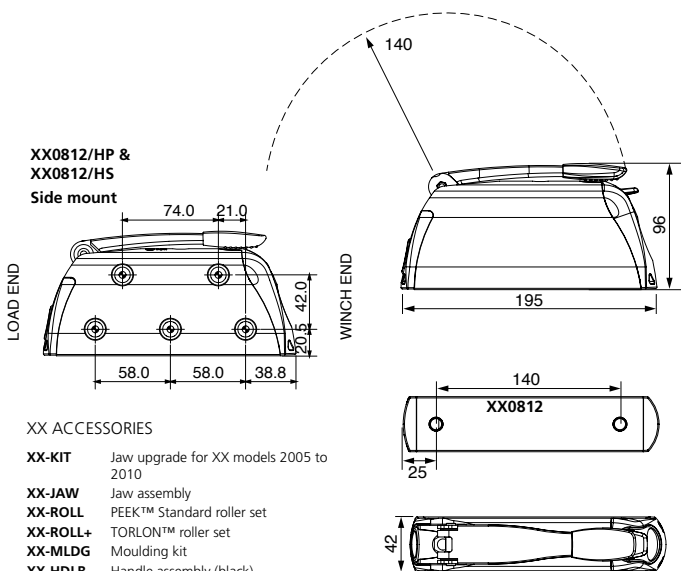

#### XX ACCESSORIES

- XX-KIT** Jaw upgrade for XX models 2005 to 2010
- XX-JAW** Jaw assembly
- XX-ROLL** PEEK™ Standard roller set
- XX-ROLL+** TORLON™ roller set
- XX-MLDG** Moulding kit
- XX-HDLB** Handle assembly (black)
- XX-LCK** Upgrade for XX0812 to XX0812/L



# XTS/XCS



XTS Lines 6-10mm ( $\frac{1}{4}$  -  $\frac{3}{8}$ "")  
 XTS Lines 8-14mm ( $\frac{5}{16}$  -  $\frac{9}{16}$ "")  
 XTS Loads up to 1000kg (2200lbs)  
 at max line diameter

XCS Lines 8-14mm ( $\frac{5}{16}$  -  $\frac{9}{16}$ "")  
 XCS Lines 12-16mm ( $\frac{1}{2}$  -  $\frac{5}{8}$ "")  
 XCS Loads up to 1200kg (2640lbs)  
 at max line diameter

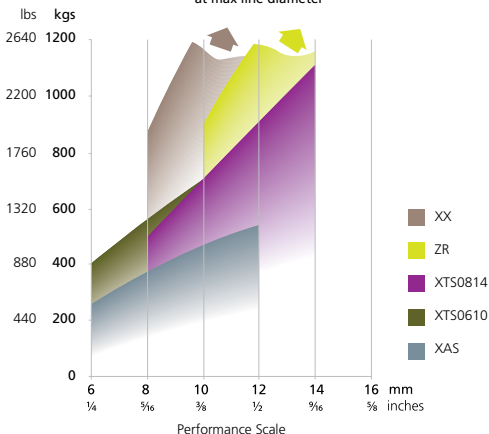

MODEL	WEIGHT	FASTENERS
XTS0814/1	545g (19.1oz)	2 x CSK M8 (2 x 5/16")
XTS0814/2	1050g (36.8oz)	4 x CSK M8 (4 x 5/16")
XTS0814/3	1585g (55.5oz)	6 x CSK M8 (6 x 5/16")
XCS0814/1	630g (22.1oz)	2 x CSK M8 2 x (5/16")
XCS0814/2	1130g (39.6oz)	4 x CSK M8 (4 x 5/16")
XCS0814/3	1610g (56.4oz)	6 x CSK M8 (6 x 5/16")

## XTS & XCS ACCESSORIES

- X-HDL** Black aluminium handle for XT, XTS, XC & XCS
- XTS-SIDE** Plastic side fairing for XTS (pair)
- XTS-SMNT** Converts standard XTS for side mounting
- XCS-SMNT** Converts standard XCS for side mounting

## XT & XC ACCESSORIES

- X-HDL** Black aluminium handle for XT & XC
- X-SIDE** Plastic side fairings for XT (pair)
- XT-KIT** Base, cam and handle

## Small diameter High Load

XTS0610, XCS0610  
 For 6-10mm ( $\frac{1}{4}$ - $\frac{3}{8}$ "") lines, optimised for 10mm ( $\frac{3}{8}$ "") lines  
 To upgrade, fit CAM-0610

## Lock-open cam XTS/L, XCS/L

When lock is engaged, the line can run freely in both directions until clutch function is needed  
 To upgrade, fit CAM-0812L or CAM-1214L, XTS0812/1L, XCS0812/1L, XCS1214/1L

## XTS, XCS, XT & XC ACCESSORIES

- CAM-0610** Cam upgrade for 6-10mm line
- CAM-0814** Cam upgrade for 8-14mm line
- CAM-1216** XC & XCS cam upgrade for 12-16mm line
- CAM-0812L** Lock-up cam upgrade 8-12mm XTS, XCS, XT & XC
- CAM-1214L** Lock-up cam upgrade 12-14mm XTS, XCS, XT & XC
- X-LBL** Handle Labels English, French, German XAS, XA, XT & XTS
- X-BASE** Base for XTS & XCS
- XTS-KIT** Base, cam and handle
- Z-LBL** High spec, high visibility handle labels

## Side Mounting Kit

Side-mountable on either side with fairing kit XTS-SMNT or XCS-SMNT for spars, side decks, and coamings

## Continuous line XTS/M

Assembles directly onto an endless mainsail furling line XTS0610/1M, XTS0814/1M, XTS0814/2M, XTS0814/3M

## Stainless steel sided XCS/SS

Mirror polished stainless steel sided versions, in single, double and triples XCS0814/SS1, XCS0814/SS2, XCS0814/SS3

# XAS

Lines 4-8mm ( $\frac{5}{32}$  -  $\frac{5}{16}$ " )

Lines 6-12mm ( $\frac{1}{4}$  -  $\frac{1}{2}$ " )

Loads up to 575kg (1270lbs)  
at max line diameter

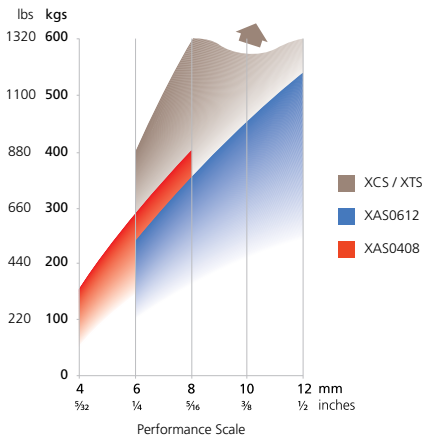

MODEL	WEIGHT	FASTENERS
XAS0408/1	270g (9.5oz)	2 x CSK M6 (2 x 1/4")
XAS0408/2	500g (17.5oz)	4 x CSK M6 (4 x 1/4")
XAS0408/3	680g (23.8oz)	6 x CSK M6 (6 x 1/4")
XAS0612/1	270g (9.5oz)	2 x CSK M6 (2 x 1/4")
XAS0612/2	500g (17.5oz)	4 x CSK M6 (4 x 1/4")
XAS0612/3	680g (23.8oz)	6 x CSK M6 (6 x 1/4")

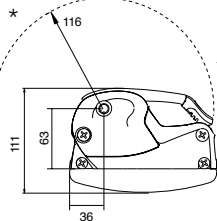

\*illustrated with sidemount kit

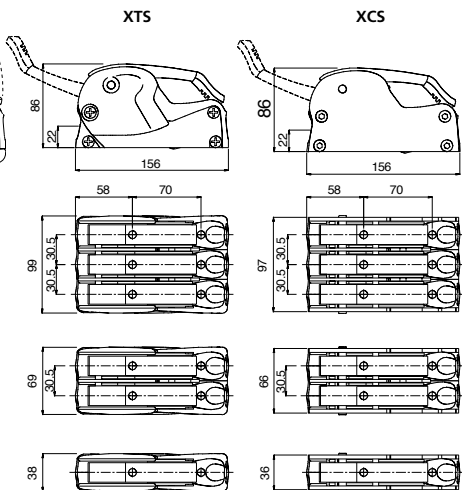

### Small Diameter/High Load XAS0408

Enhanced performance on smaller lines  
4-8mm (5/32-5/16").

recommended for sportsboat and other small boat/  
higher load applications.

Check rope size/load graph

XAS0612 may be converted for small diameters with  
special base unit XAS-BASE0408

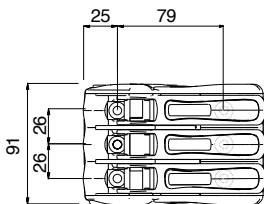

### Side Mount XAS

Side fixing is a neat solution for spars, side decks, and  
coamings XAS0612-HS and XAS0612-HP

Side fairing accessory XAS-SMNT to install a single  
XAS on its side

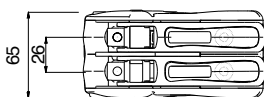

### Continuous line XAS/M

Assembles directly onto an endless mainsail furling  
line

Models: XAS0612/1M, XAS0612/2M, XAS0612/3M

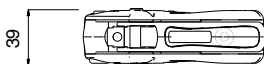

### XAS & XA ACCESSORIES

**CAM-XAS** Standard replacement cam - for  
XAS and XA

**X-LBL** Handle Labels English, French,  
German for XAS, XA, XT, XTS &  
XCS

**SA29** XAS & XA Spring Arm

**XAS-BASE0408** Base upgrade for smaller  
diameter line - for XAS and XA

**XAS-BASE0612** Base upgrade - for XAS and XA

**XAS-SMNT** Sidemount kit (inc fasteners)  
XAS only

**XAS-HDL** Handle - XAS only

**XAS-SIDE** Sidefairings - XAS only

**XAS-KIT** Base, cam, sides and handle

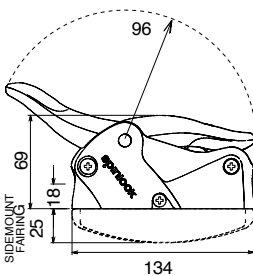

### PXR0206/VP

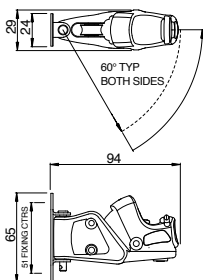

### PXR0206/SW

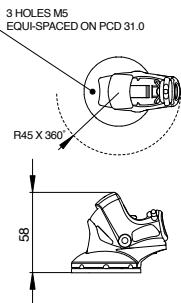

### PXR0810/SW

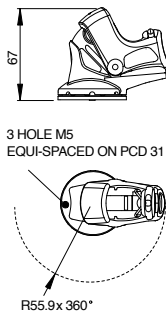



# PXR



**PXR0206 Lines 2-6mm ( $\frac{3}{32}$  -  $\frac{1}{4}$ " )**  
**PXR0206 Loads up to 140kg (616lbs)**  
 at max line diameter



**PXR0810 Lines 8-10mm ( $\frac{5}{16}$  -  $\frac{3}{8}$ " )**  
**PXR0810 Loads up to 200kg (440lbs)**  
 at max line diameter

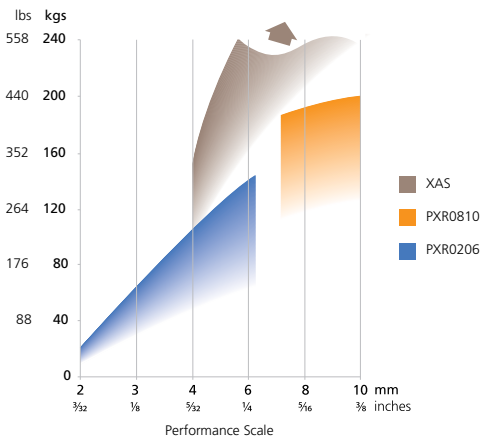

**PXR0206**

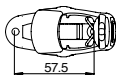

**PXR0810**

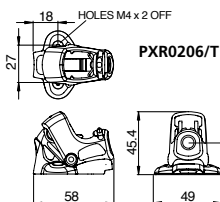
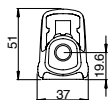
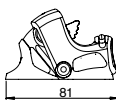
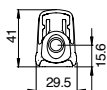

**PXR0206/T**

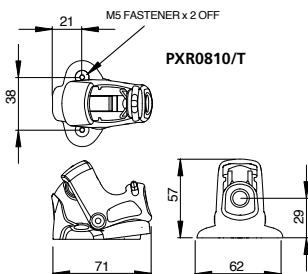

**PXR0810/T**

MODEL	WEIGHT	FASTENERS
PXR0206	43g (1.5oz)	2 x CSK M4 (2 x 5/32")
PXR0810	84g (2.9oz)	2 x CSK M5 (2 x 3/16")
PXR0206/SW	77g (2.7oz)	3 x CSK M5 (3 x 3/16")
PXR0810/SW	124g (4.3oz)	3 x CSK M5 (3 x 3/16")
PXR0206/VP	97g (3.4oz)	2 x PAN (or rivet)
PXR0206/T	53g (1.9oz)	2 x CSK M4 (2 x 5/32")
PXR0810/T	101g (3.5oz)	2 x CSK M5 (2 x 3/16")

## PXR ACCESSORIES

**PXR-BRACKET**  
 Mast mount for PX & PXR



# DECKWARE



## DECKWARE ACCESSORIES

<b>BHD-RAK</b>	38g CO2 cylinder and United Moulders MK5i Capsule and retaining clip, for pre 07 Deckware lifejacket harness	<b>DW-MAK</b>	Deckvest manual activation conversion kit
<b>DW-RAK</b>	33g CO2 cylinder and United Moulders MK5i Capsule for the Deckvest lifejacket harness	<b>BHD-LHT</b>	SOLAS approved Aquaspec AQ98 flashing light
<b>DW-RAH/150</b>	33g CO2 cylinder for Hammar Hydrostatic 150N Deckvest	<b>DW-DTS/2</b>	Deckvest thigh straps for size 2
<b>DW-RAH/275</b>	60g CO2 cylinder for Hammar Hydrostatic 275N Deckvest	<b>DW-DTS/3</b>	Deckvest thigh straps for size 3
		<b>BHM-LCP</b>	Replacement Kevlar anti abrasion covers for Mast Pro Harness BHM-PSG (pre 2008)
		<b>DW-MPE</b>	Replacement elastic leg straps for Mast Pro harness (2008 onwards)

## DECKVEST SIZE GUIDE



### APPROVALS

CE approved ISO 12402-3 lifejacket  
ISO 12401 deck harness EC & US patents pending

\* Please note that the Hammar 275 Deckvest is only available in sizes 2 & 3

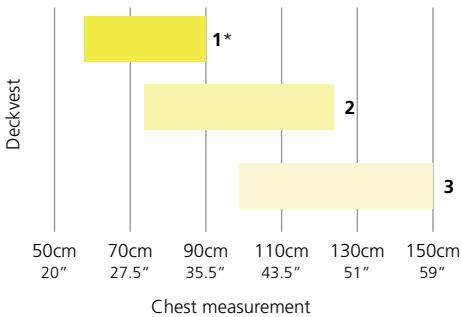

## ZERO SIZE GUIDE



### APPROVALS

CE approved ISO 12402-5

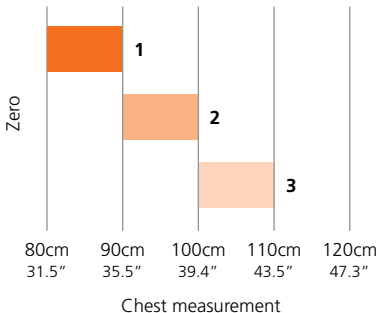

# The 10 Best Ways to Prevent Man Overboard

*'In no circumstances are you better off in the water than out of it...'*

Essentials of Sea Survival, Golden & Tipton

- 1 Tighten lifelines and jacklines.** These lines are essential for containing a fall safely. Keep them taut, replace any damaged or corroded terminations; specify low stretch flat jacklines and remove them at the end of each season.
- 2 Provide secure strong points and handholds.** Vital at workstations, and for moving and clipping inboard of the jackline and especially on bigger, wider decks.
- 3 Keep a good foothold.** Wear footwear that grips well on a heeled deck when wet. Fit non-skid deck patches where necessary.
- 4 Wear your own combined harness and lifejacket.** Wearing a lifejacket on its own will never keep you out of the water - only a clipped-on harness will.
- 5 Keep it securely fitted.** If your lifejacket harness is unfastened or flapping around your waist it can't be a reliable harness or a reliable lifejacket.
- 6 Wear a light, compact safety line** with an overload indicator. As clips can't always be released under load, carry a dedicated line cutter in case you need to disconnect fast.
- 7 Always clip on** when sailing short handed, at night, in poor visibility or in heavier weather. Novices, children and the less able should clip on in all weathers.
- 8 Do it out of consideration** for the skipper, fellow crew and those who might have to come to your rescue.
- 9 Look after your kit.** Webbing fibres degrade in strong sun, in damp salt conditions and especially from abrasion. Destroy any safety line showing wear or contamination or after any heavy fall. Store all lifejackets, harnesses and safety lines in a dry place.
- 10 Trust your own kit.** When you look after your own lifejacket harness and safety line you can trust them more than anything borrowed.

This advice reflects the present consensus of the Spinlock special projects team and expert opinion gathered from friends at the highest levels of international sailing and sea safety.

**Register online now, for your 5-Year Deckvest Warranty\***

\*Please note that the free 5 year warranty applies only if your Deckvest has been registered online within 30 days of purchase. Without registration, the standard 2 year warranty period applies.

**InterDist**

16 rue des petits champs  
35400  
Saint Malo

📞 +33 299 195 454  
☎ + 33 299 195 455  
✉ info@interdist.fr  
🌐 www.interdist.fr

**spinlock**  
**2011**  
the experts in rope holding